



Engineered for use with load cells, tanks, hoppers, silos and platforms

High accuracy at a very low price

IP54 protection -front panel-

Low overall dimensions facilitate its assembly in switchboards

Programmable by keyboard

Parameters are stored in 50 different recipes easily recalled from the keyboard

It allows to manage both automatic weighing sequences with limit control and single-component batching processes  
-loading and/or unloading-

RS232 or RS422/RS485 output connected with PLC and PC

**TECHNICAL CHARACTERISTICS MC 102**

Trasducer input voltage:	5 Vdc 120 mA (max 8 cells 350 Ohm in parallel)
Measuring range:	-3.9 ÷ +3.9 mV/V
Input sensitivity:	0.02 µV/ per count
Linearity:	<0.01% of full scale
Gain drift:	<0.0003% full scale/ °C
A/D Converter:	24 bit
Internal resolution:	> 16.000.000 counts
Visible resolution:	99.999 division visible on net weight
Set decimal:	0.0 ; 0.00 ; 0.000; 0.0000
Filter:	0.2 ÷ 25 Hz adjustable
Tool voltage:	230 Vac ±10% - 50/60 Hz absorbed power 7 W (115 Vac on demand)
Temperature range:	-10 ÷ +50°C
Storage temperature:	-20 ÷ +70°C
Logic output:	4 relays (NA) Max. 115 Vac/30 Vdc 0.5 A each
Logic input:	3 optoisolated 12 Vdc/24 Vdc PNP
Serial door:	COM1: RS232 half duplex COM2: RS422/RS485 half duplex
Transmission distance:	15m (RS232C), 1000m (RS422 e RS485)
Protocol:	ASCII, Modbus, Printers Custom P190 o FT190, EPSON
Baud rate:	300 ÷ 115200 (adjustable)
Regulatory compliance:	EN61000-6-3, EN1000-6-2, EN61010-1
Insulation:	Class II
Dimensions:	144 x 72 x 120 mm (W x H x D)
Drilling template:	139 x 67 mm (W x H)
Electrical connection:	Terminal screw pass 5.08 mm
Optional dosage software:	1 component in the loading or unloading up to 50 programmable recipes
Optional analog output:	Optically isolated 16-Bit Voltage: 0÷5 or 0÷10V (R>10K Ohms); Current: 0÷20 o 4÷20mA (R < 300 Ohm); Linearity: 0.03% F.S.
BCD optional output:	Through external module



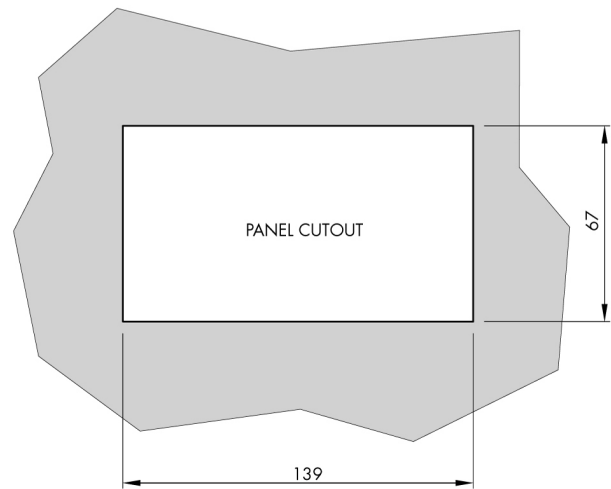
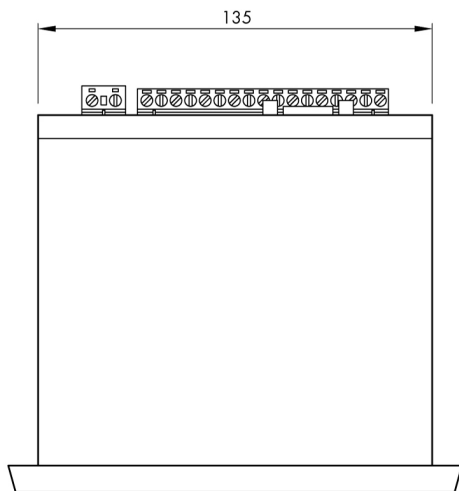
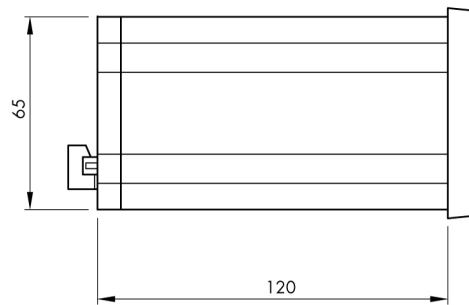
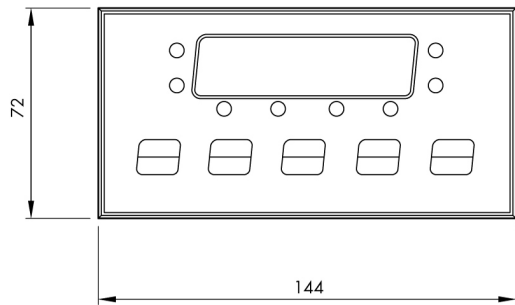

**SCIGATE AUTOMATION (S) PTE LTD**

No.1 Bukit Batok Street 22 #01-01 Singapore 659592

Tel: (65) 6561 0488

Fax: (65) 6562 0588

Email: sales@scigate.com.sg

Web: www.scigate.com.sg

Business Hours: Monday - Friday 8.30am - 6.15pm

